

Y.TU 450-D08

Bipolar metal-ceramic X-ray tube

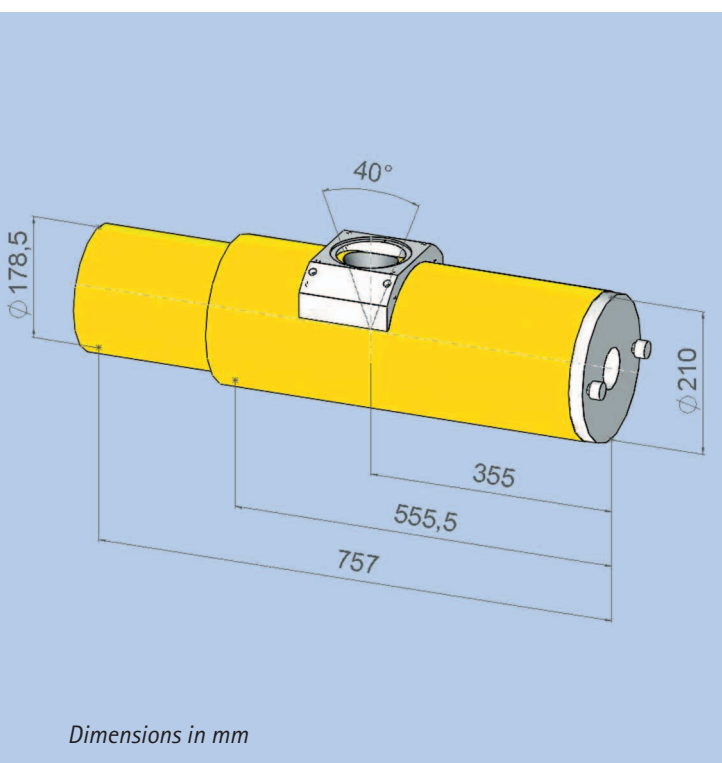

YXLON's 450 kV bipolar metal-ceramic X-ray tubes are specially developed to inspect thick sections of high density materials, e.g. iron and steel castings. Due to a low absorbing beryllium window and low kV capability Y.TU 450-D08 is also suited to inspect thin sections of low absorbing materials.

Providing a high level of mechanical and electrical strength YXLON X-ray tubes are both compact and lightweight.

Together with the YXLON generators, power supplies and control units the X-ray tubes form powerful systems setting the standards in reliability, lifecycle and service.

YXLON. The reason why.

- high penetration power
- long lifecycle
- high reliability
- extensive service

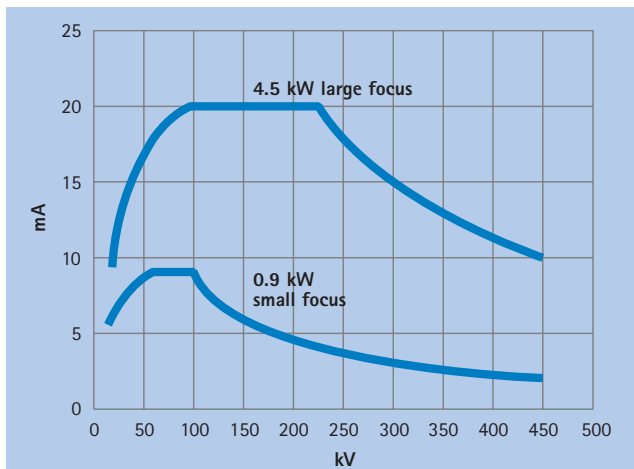
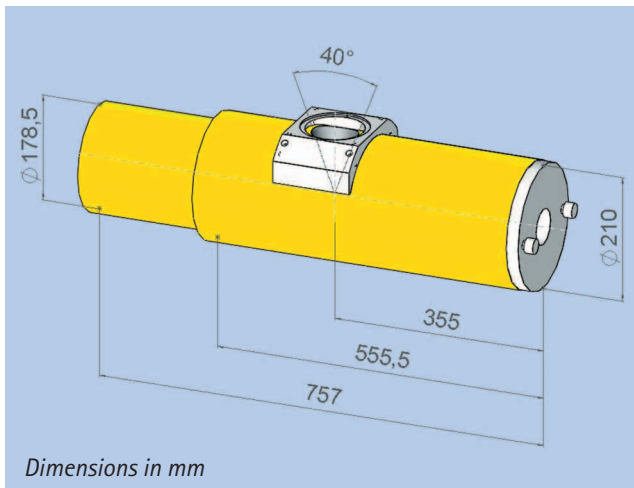

Loading data: Shown are the max. permissible anode currents. Within the X-ray system these anode currents may be limited by power suppliers or generators.

Max. tube voltage	450 kV
Focal spot size (acc. EN12543)	2.5 mm / 5.5 mm
Max. power (fine / standard focus)	0.9 kW / 4.5 kW
Max. tube current at 450 kV	2 mA / 10 mA
Emergent beam angle	40 °
Inherent filtration¹	5 mm Be + 3 mm Al + 0.5 mm Cu
Leakage radiation²	< 5 mSv/h
Coolant	Oil
Max. inlet temperature	50 °C
Min. flow rate	14 l/min
Environmental conditions	
Operation temperature	0 °C...+40 °C
Storage temperature	-25 °C...+70 °C
Relative humidity	
- Operation	95 %
- Storage	95 %
Weight	95 kg
H.V. connection	Flange R28
Approval	NF C74-100
Order no.	9421 172 33403

¹ Al-filter removable by using tools;
Al-filter acc. DIN 54113 and SSI FS1989:2;
Cu-filter enclosed

² Measured at 1.0 m distance from the focal spot with X-ray port closed and X-ray tube operating at full load.